



STEPPER-CONTROLLED 2-WAY PROPORTIONAL VALVES



Utilizing the industry's most robust and powerful linear actuator, the stepper-controlled proportional high flow valve, SCPV, is ideal in critical applications where precise gas delivery for medical, analytical, and industrial automation is needed. Those applications requiring high resolution, high flow, low hysteresis and variable control of inert gases. In addition, the simple design but unique modifications possible allow for custom flow curves more specific to your application needs.

- Less than 2% hysteresis
- Excellent linearity—less than 2.5% of full-scale
- 2 ms reaction time
- Millions of cycles
- Holds position for power savings or at a loss of power

Characteristic Curve
Flow Rate for SCPV-1-3 @ 100 psig

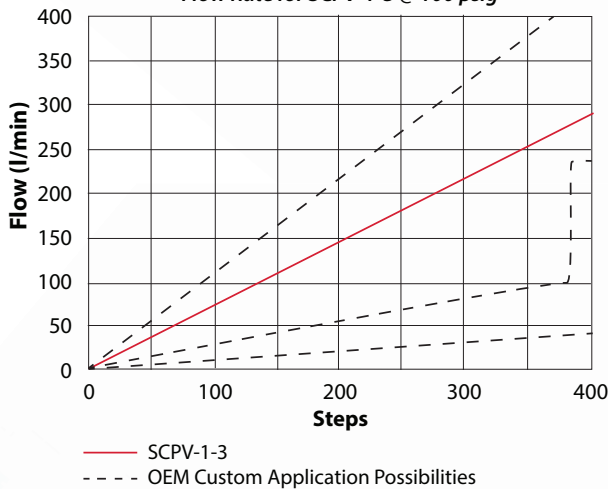

SPECIFICATIONS

Medium	Air or compatible gases
Typical Cycle Time for Full Travel	0.95 seconds @ 100% duty cycle 0.55 seconds @ 25% duty cycle <i>(full open to full close or full close to full open)</i>
Wetted Material	Stainless steel, aluminum, brass, acetal and FKM*
Pressure Range	Vac. to 100 psig*
Flow Range	0 to 280 l/min <i>(Special configurations over 500 l/min available*)</i>
Flow Resolution	0.7 l/min per step
Position Resolution	0.001" per step
Temperature Range	32 to 184°F
Driver	Bipolar chopper drive required
Needle	3.5°
Supply Voltage to Motor	5 VDC
Response Time	0.95 seconds fully-open to fully-closed
Mounting	In-line, manifold or cartridge
Power Consumption	3.85 watts nominal only during adjustment Zero power consumption to maintain position
Seals	FKM standard, others available*
Option	Rubber seat <i>(add -R Suffix)</i>
More Details	clippard.com/link/scpv

Part No. Description

SCPV-1-3	Proportional Valve, In-Line
SCPV-1-3M	Proportional Valve, Manifold
SCPV-1-3C	Proportional Valve, Cartridge

Stepper-controlled linear actuator with acme lead screw

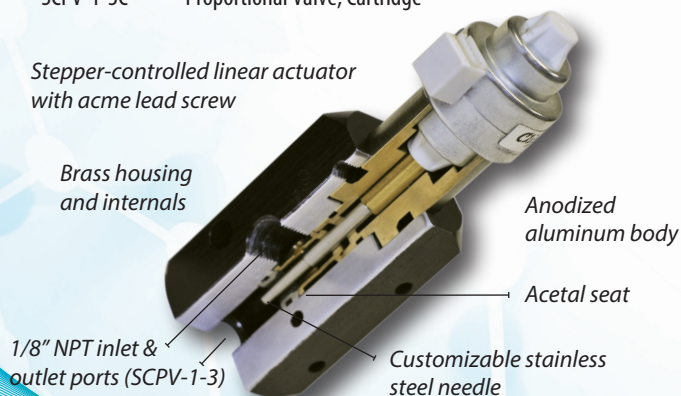

* This product is highly modifiable for OEM applications—including alternate body materials, flow profiles, and more. Clippard has successfully produced special configurations of the SCPV with flows over 700 l/min @ 100 psig.

STEPPER-CONTROLLED & DRIVER

PROPORTIONAL VALVE

LINEAR ACTUATOR CHARACTERISTICS

Wiring	Bipolar
Current/Phase	385 mA
Motor Voltage	5 VDC
Resistance/Phase	13 ohms
Inductance/Phase	8.08 mH
Power Consumption	3.85 watts
Temperature Rise	135°F
Insulation Resistance	20M ohms

Wiring Harness (included)

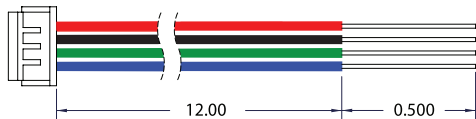

Pin	Color	Pin	Color
1	Red (A+)	3	Green (B-)
2	Black (A-)	4	Blue (B+)

Maximum Step Pulse Frequency vs. Operating Pressure

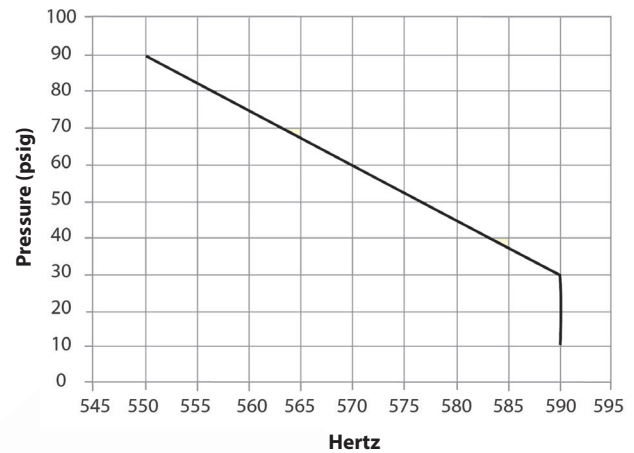

SCPVD BI-POLAR STEPPER MOTOR DRIVER

The SCPVD is a bi-polar stepper motor driver board which can be used for stepper motors up to a max 2A/phase. It is based on the Allegro A4988 motor driver. The driver requires a motor drive voltage of 7 to 35 volts. An external controller is required to deliver step and direction signals to the driver board. The SCPVD is capable of micro-stepping and defaults to a 16th step micro-stepping mode. The step mode as well as several other options such as sleep, enable, and reset can be toggled on and off.

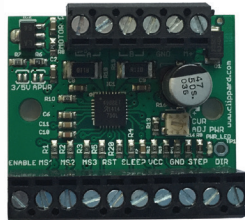

- Medical, analytical, and industrial gas mixing
- Anesthesia equipment
- Precision flow control
- Cuff/bladder pressure control
- Process flow control
- Variable speed control
- Automation of needle valve



For more details, visit clippard.com/scpv

Part No.	Description
SCPVD-1	SCPVD-1 Valve Driver

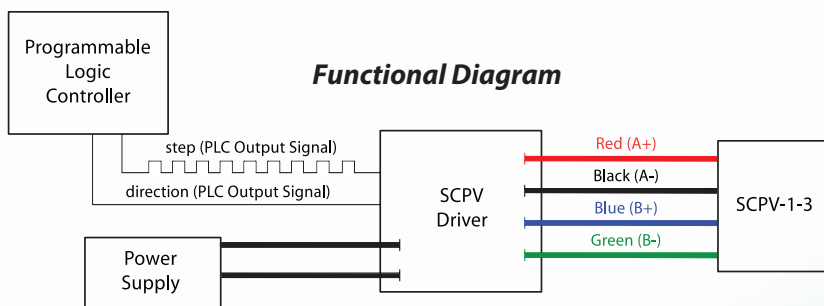

877-245-6247 | clippard.com

CLIPPARD INSTRUMENT LABORATORY, INC. • ISO 9001 • TDS 3.11 V.2
For warranty and disclaimer information, visit clippard.com/warranty

